

Litter Bin

Ref. 20 0723N

Street Furniture
Contemporary Range

Sineu Graff : Intelligent Design
for the town of tomorrow



➤ Presentation

Contemporary litter bins are part of a complete range of street furniture in perforated metal, made entirely of steel. It is semi-circular in shape and is designed to be mounted on a wall or a safety rail.

This furniture has been designed and manufactured by Sineu Graff, experts in urban landscaping, in accordance with a sustainable development approach.

➤ Description

The bin is made up of a body, a door in perforated 3mm thick painted galvanized steel, a lid in 5mm thick painted galvanized steel and a stainless steel bucket.

Steel parts are zinc plated, then they undergo our powder blast process (after cleaning and shot blasting, they are coated with a first coat of epoxy powder, and then with a second coat of polyester powder).

The bin lid is articulated by means of a hinged pin.

Closing is automatic, while opening is done via a triangular key.

Lid closure is buffered by 2 rubber stops.

4 anchoring points.

Capacity: 50 litres.

Delivered assembled.

Weight: 30kg.

➤ Dimensions

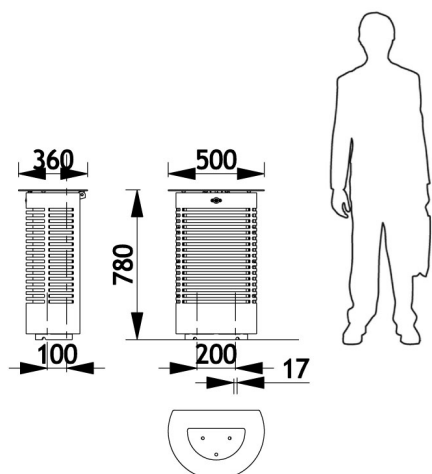

Street Furniture



SINEU GRAFF partner in Norway :

Laud Produkter AS

Salg: Rosenkrantz gt 15, 0160 Oslo

Administrasjon: Pb. 2, 4951 Risør

Org.nr: 911933500 - Telefon: 21904020

SINEU GRAFF info@sineugraff.com - www.sineugraff.com