

# Litter Bin

Ref. 20 0555N

Street Furniture  
Classical Range

Sineu Graff : Intelligent Design  
for the town of tomorrow



## ➤ Presentation

This litter bin from the Classic range is oblong in shape. Its wooden cladding gives it a natural and warm appearance and it will easily integrate into all your urban spaces and parks.

This furniture has been designed and manufactured by Sineu Graff, experts in urban landscaping, in accordance with a sustainable development approach.

## ➤ Description

The bin is made up of a body with wooden slats, an upper rail in 2.5mm thick painted galvanized steel, a lower rail with a bottom in 2.5mm thick painted galvanized steel, a painted galvanized steel framework with 2 2.5mm thick triangular posts, a liner holder and a triangular lock.

Plate anchored versions have 6mm thick painted galvanized steel anchoring plates.

After the application of a flow coat, the wood is coated with solvent-free water-based emulsion stain.

The wood used is certified and sourced from well-managed forests.

Steel parts are zinc plated, then they undergo our powder blast process (after cleaning and shot blasting, they are coated with a first coat of epoxy powder, and then with a second coat of polyester powder).

4 anchoring points.

Capacity: 44 litres.

Delivered assembled.

Weight: 30kg.

## ➤ Dimensions

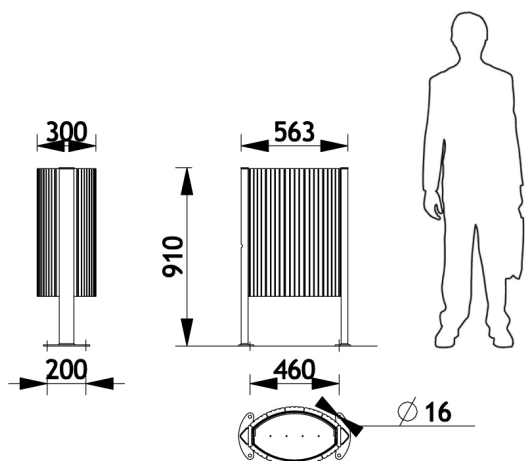

**LAUD**  
PRODUKTER

Møblering av offentlig rom



Street Furniture



**SINEU GRAFF partner in Norway :**  
Laud Produkter AS  
Salg: Rosenkrantz gt 15, 0160 Oslo  
Administrasjon: Pb. 2, 4951 Risør  
Org.nr: 911933500 - Telefon: 21904020

SINEU GRAFF info@sineugraff.com - www.sineugraff.com