



# Link

Many meters of conviviality

**81%** of city dwellers would visit city centre more often if there were more places of conviviality and meeting places in the public realm.

Study : Les Français et l'aménagement de l'espace urbain - Kantar Public | L'Ameublement Français (oct 2017).



**ADDITIONAL  
INFORMATION**

Flash with your  
smartphone

[www.sineugraff.com](http://www.sineugraff.com)

# Link

## Urban furniture for friendly towns

For over 40 years, Sineu Graff has been supporting town planners and designers and paying close attention to changes in the use of urban spaces. While towns today are perfectly functional, and their safety, mobility and cleanliness needs are being met, inhabitants feel they lack meeting places and centres of conviviality in the public space.

People tend to fill that gap by turning to commercial areas. Shopping centres, cafés, restaurants and cinemas have become places where town-dwellers choose to meet each other. In order to foster conviviality in public spaces, Sineu Graff has imagined a large Street Table around which people can sit, share a meal or just take a break. Our ambition is to offer solutions that will foster new uses, help the population develop innovative forms of collective city life and promote greater social cohesion. Creating friendlier towns.

In order to support current behaviours and lifestyles, Sineu Graff has created a whole range of furniture that springs from the Street Table, called Link: picnic decks, standing table, seats sets and low tables, etc. These pieces are at home in parks and in squares, each with its own function and use.

**Reinvent your town with Link !**

Vincent SCHALLER - President

# Sineu Graff

# Many meters of conviviality

To develop conviviality in the public realm, Sineu Graff naturally turned its attention to the table, which is spontaneously associated with meeting and sharing.

**The Street Table** has been designed to breathe life into towns and make room for exchange. It breaks with the codes of urban furniture and appeals to inhabitants in an immobile architectural environment.

**The Street Table** is designed for living spaces, meeting areas (with reduced traffic speed) and new eco-districts, to make these areas more desirable, and to make up for their density.

**The furniture is universal and easy to be understood as regards to its use.** People come to it immediately for their lunch break, or to sit for a while, alone or with friends and family.



## ADDITIONAL INFORMATION

[contact@sineugraff.com](mailto:contact@sineugraff.com)

Tel. : 03 88 58 74 58



# The **Street Table | Link**

**The Street Table can be extended infinitely** with its modular system: the initial module is 2 metres long, and any number of 2-metres extensions can be added to it. The seats are placed freely around the table.



## **An eco-designed range !**

Optimised transport and packaging :  
the seats slide inside the table.



Furniture shown is in **ash**  
with clear autoclave treatment



All Link furniture are available in **ash** with clear autoclave treatment or in **exotic hardwood** without stain.



The legs are in galvanised steel, not colored or **in zinc and powder coated steel** (Colours can be selected from the RAL shades or other textured shades from the Akzo Nobel Futura range).

# Community life

The Street Table has been designed to meet all requirements for community life: **its seats are independent and therefore more accessible**. There is no need to climb over a bench. The seats can be placed freely along the table, with the possibility to leave a clear area to accommodate a wheelchair or pushchair. Everybody can sit around a table with generous proportions. Nothing is unmovable, and combinations can be invented to give each member a place.



Sineu Graff has developed the Street Table in collaboration with Philippe Riehling, sustainable design specialist. The idea is **to revisit and update the picnic table**, making it clean, elegant and convivial for effective integration into all types of environment. While the materials (ash and galvanised steel) pay homage to the classic picnic tables of the country and green spaces, the long lines of the Street Table allow visual continuity that becomes stronger as the number of furniture items increases. In accordance with **an eco-design approach**, the consumption of material is reduced through simple shapes, and transport is optimised by nesting the seats inside the table.

# The **components** of the **Street Table | Link**

The Link range is made of identical dimensions wooden slats on a galvanised steel structure.  
The Street table can be extended without length limit, thanks to the 2-metres long extensions.



Street Table| BELLEGARDE SUR VALSERINE (01 - France)

## > Street Table

L. 2000 mm / P. 855 mm / H. 735 mm  
4 anchoring points - weight 89 kg

.....

Ref. 11 0510

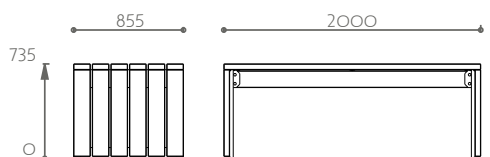

● Furniture shown is in **ash**  
with clear autoclave treatment



## > End extension

L. 2000 mm / P. 855 mm / H. 735 mm / 2 anchoring points - weight 71 kg  
The extension is fixed to the table by galvanised steel brackets 3 fixing points.

This model has to be positioned at the end as it has no holes.

Ref. 11 0511 EXT

Furniture shown is in ash with clear autoclave treatment



## > intermediate extension

L. 2000 mm / P. 855 mm / H. 735 mm  
2 anchoring points - weight 71 kg  
The extension is fixed to the table by galvanised steel brackets 3 fixing points.

Has to be positioned between 2 elements. It also has holes at the end so that it can be combined with another extension.

Ref. 11 0511 INT



Furniture shown is in ash with clear autoclave treatment

## Assembly principle of a 6 m table (or more)



1x street table  
11 0510 INT

1x or more  
intermediate(s) extensions(s)  
11 0511 INT

1x end extension  
11 0511 EXT



# The Seatings | LINK

## > Stool

L. 435 mm / P. 420 mm / H. 430 mm - 4 anchoring points. - weight 12 kg

Ref. 11 0501

Furniture shown is in **ash**  
with clear autoclave treatment

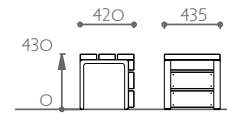

## > 2 place bench

L. 1000 mm / P. 420 mm / H. 430 mm - 4 anchoring points. - weight 24 kg

Ref. 11 0502

Furniture shown is in **ash**  
clear autoclave treatment



## > 3 place bench

L. 1500 mm / P. 420 mm - H. 430 mm - 6 anchoring points. - weight 32 kg

Ref. 11 0503

Furniture shown is in **exotic hardwood**  
without stain





High table and perch seat & Street Table | DUNKERQUE (59 - France)



Street Table | OLLIOULES (83 - France)



Street Table | COLMAR (68 - France)



Street Table | VALENCIENNES (59 - France)



Street Table | MÂCON (71 - France)



Street Table | REIMS (51 - France)

# The **Seatings** with backrest | **LINK**



3 place seat | EPINAL (88 - France)

## > Chair

L. 435 mm / P. 538 mm / H. 804 mm - 4 anchoring points - weight 23 kg

Ref. 11 1501



Furniture shown is in **ash**  
with clear autoclave treatment

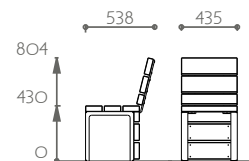

## > 2 place seat

L. 1000 mm / P. 538 mm / H. 804 mm - 4 anchoring points - weight 33 kg

Ref. 11 1502



Furniture shown is in  
**exotic hardwood** without stain

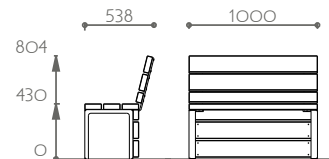

### > 3 place seat with half backrest

L. 1500 mm / P. 538 mm / H. 804 mm - 6 anchoring points - weight 42 kg

Ref. 11 1513

The half backrest can be positioned either on the right or on the left.



Furniture shown is in **ash** with clear autoclave treatment

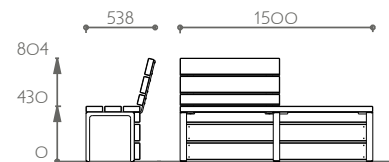

### > 3 place seat full backrest

L. 1500 mm / P. 538 mm / H. 804 mm - 6 anchoring points - weight 49 kg

Ref. 11 1503



Furniture shown is in **exotic hardwood** without stain

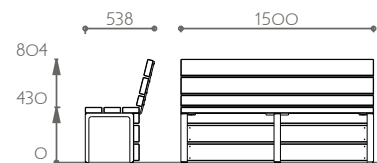

Street Table | EPINAL (88 - France)



3 place seat | LANGESUND (Norway)

Photographic credit: Anne Lena Tande Sandersen

# Supporting new **behaviours**



**The Street Table has inspired a complete furniture range LINK.**

In collaboration with Philippe Riehling, we have developed furniture that can support urban uses and tone with a number of environments.

Propose new postures with the lounge and its shelf, the picnic deck or the table and seat sets, improve the comfort of your Street Table by adding a sunshade and complete your layout with the Link litter bin and bicycle guard.

With Link, you have the opportunity to create convivial spaces in the heart of our cities.



# The picnic **Deck**

## > Deck

L. 3200 mm / P. 2015 mm / H. 375 mm - 8 anchoring points. - weight 217 kg

Ref. 11 0540

Furniture shown is in **ash** with clear autoclave treatment

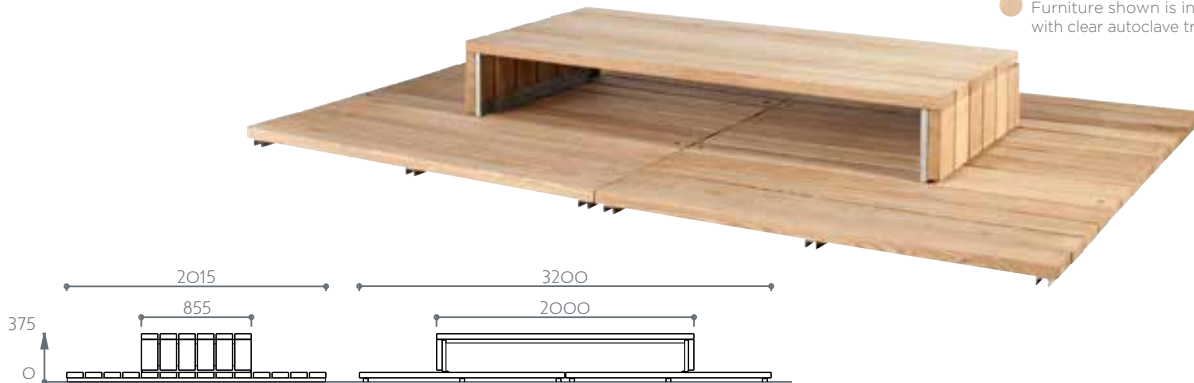

Picnic deck | STRASBOURG (67 - France)



All Link furniture are available in **ash** with clear autoclave treatment or in **exotic hardwood** without stain.



The legs are in galvanised steel, not colored or **in zinc and powder coated steel** (Colours can be selected from the RAL shades or other textured shades from the Akzo Nobel Futura range ).

# The **Lounger**

## > **Lounger**

L.1819 mm / P. 710 mm / H. 963 mm - 6 anchoring points - weight 53 kg

Ref. 11 1550

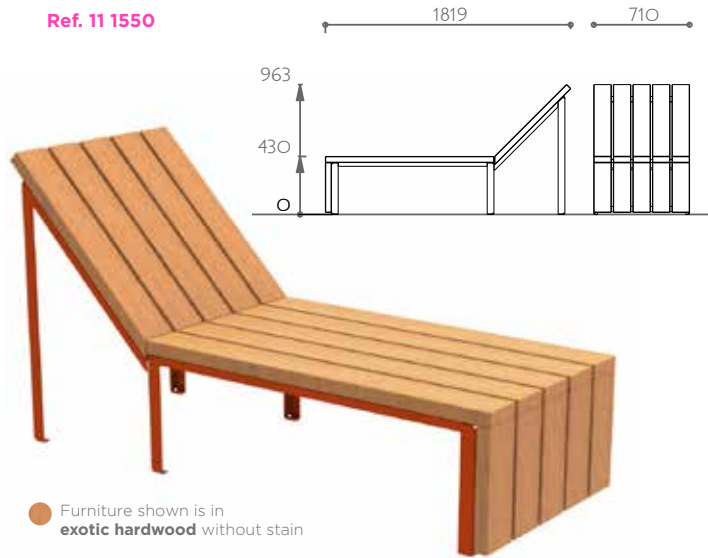

Furniture shown is in **exotic hardwood** without stain



## > **Shelf for lounger**

L. 420 mm / P. 260 mm / H. 710 mm - 4 anchoring points - weight 17 kg

Ref. 11 0555

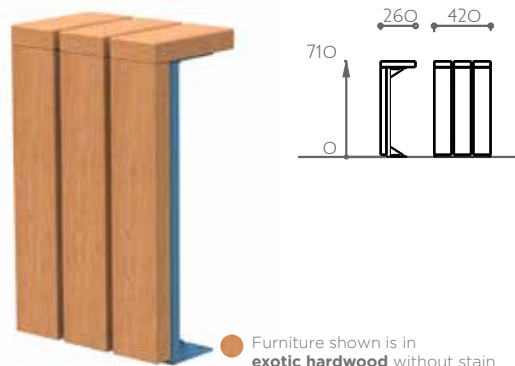

Furniture shown is in **exotic hardwood** without stain



Loungers | LANGESUND (Norway)

Photographic credit: Anne Lena Tande Sandersen

> Loungers | Combinations suggestions



Furniture shown is in  
**exotic hardwood** without stain



Loungers - DARDILLY (69 - France)



Loungers - ÉPINAL (88 - France)



Loungers - VITROLLES (13 - France)

# High tables sets

## > Perch seat and high table set

Made up of 1 high table and 3 perch seats. Ø 1800 mm



Furniture shown is in ash with clear autoclave treatment

## > High table

L. 420 mm / P. 435 mm / H. 1100 mm  
4 anchoring points. - weight 40 kg

Ref. 11 0530

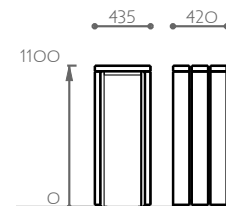

## > Perch seat

L. 420 mm / P. 267 mm / H. 879 mm  
4 anchoring points. - weight 20 kg

Ref. 11 0504

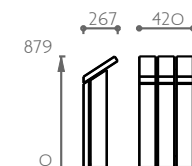

## > High table lg 2000 mm

L. 2000 mm / P. 565 mm / H. 1104 mm  
4 anchoring points  
weight 84 kg

Ref. 11 0515

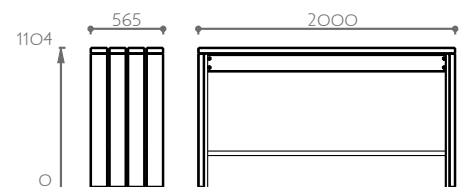

## > High table set

Made up of 1 high table L. 2000 mm and 1 high bench.



Furniture shown is in exotic hardwood without stain

## > Perch bench

L. 1500 mm / P. 275 mm / H. 795 mm  
4 anchoring points. - weight 34 kg

Ref. 11 0505

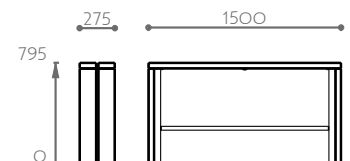

# The **Low table** set

## > The low table set

Made up of 1 low table and 2 stools.  
L. 1995 mm / P. 855 mm / H. 430 mm

.....



● Furniture shown is in **exotic hardwood** without stain

## > Low table

L. 855 mm / P. 855 mm / H. 370 mm  
4 anchoring points. - weight 40 kg

.....

Ref. 11 0520



● Furniture shown is in **ash** with clear autoclave treatment

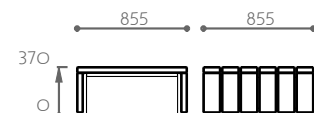

## > Stool

L. 435 mm / P. 420 mm / H. 430 mm  
4 anchoring points. - weight 12 kg

.....

Ref. 11 0501



● Furniture shown is in **ash** with clear autoclave treatment

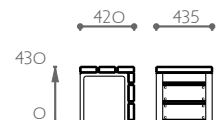

Low table set | CERNAY-LES-REIMS (51 - France)

# The Sunshade

The Link sunshade was developed adopting an environmentally friendly approach to design, in line with the existing Link range. The sunshade enables the installation of the street table in any environment to make those moments of relaxation and sociability last and last.

## > Sunshade 3 panels

L. 4725 mm / P. 2718 mm / H. 2606 mm  
16 anchoring points - weight 432 kg

Ref. 11 2503

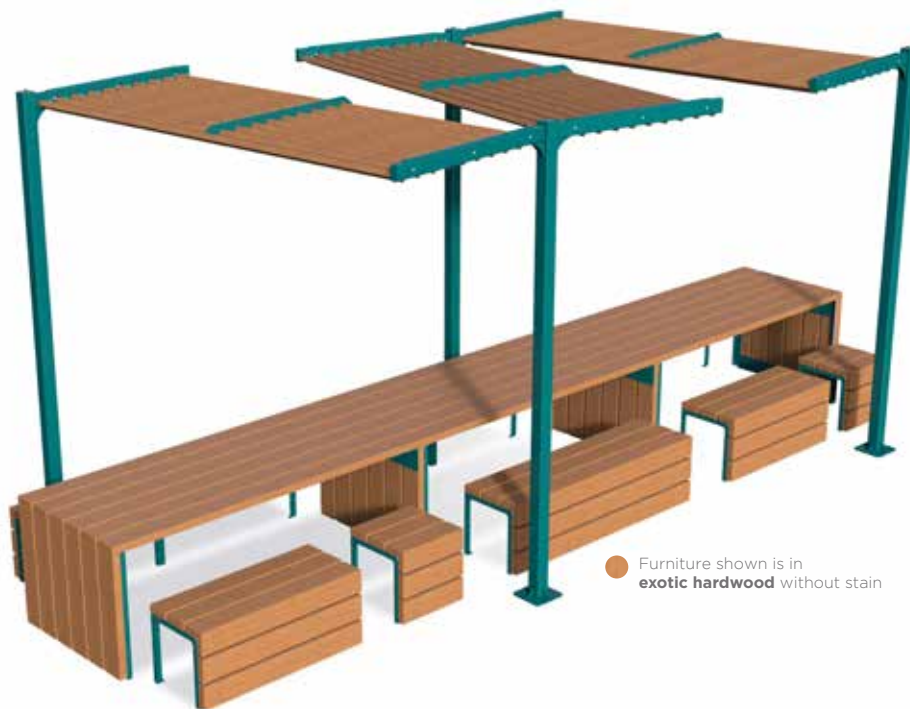
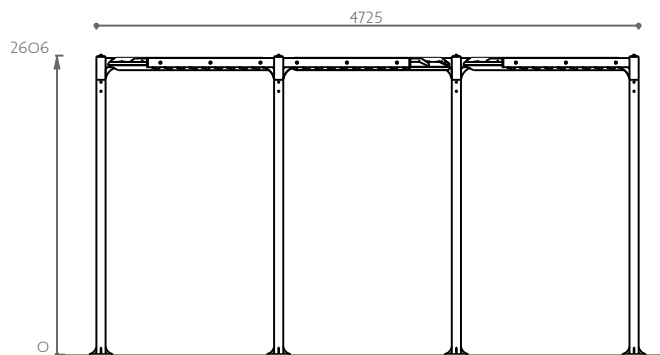
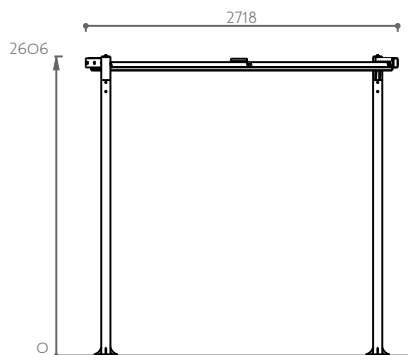

Furniture shown is in exotic hardwood without stain



Sunshade 3 panels | BÈGLES (33 - France)

# Projected shades at different times of the day

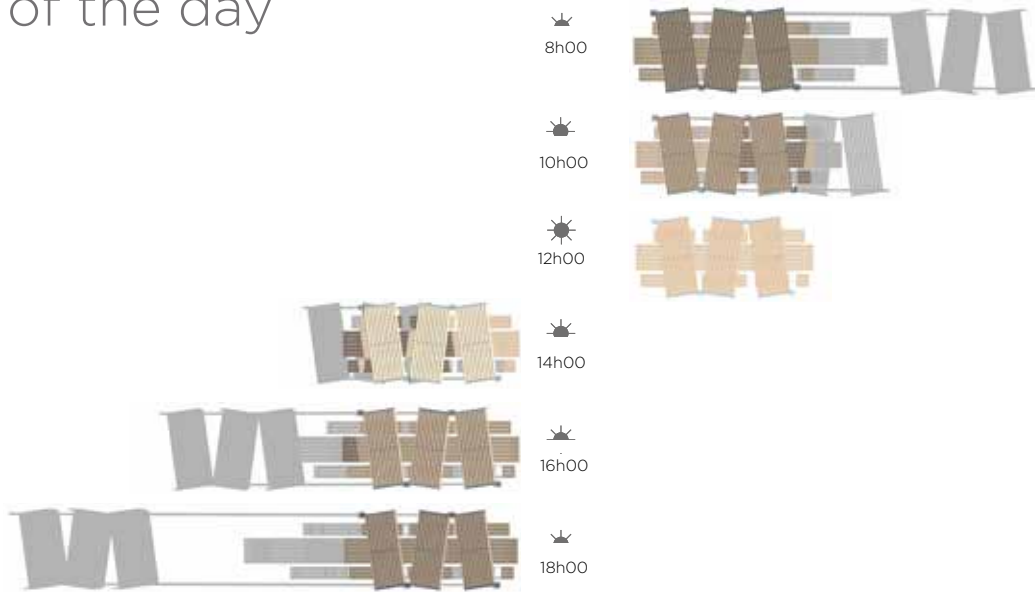

Street Table with sunshade 5 panels | BÈGLES (33 - France)



# Litter bin & Bicycle guard

## > Litter bin

Dim. 450 x 450 mm / H. 860 mm - 4 anchoring points  
Bag holder > capacity 80 L - weight 41 kg  
Liner > capacity 60 L - weight 44 kg

.....

Ref. 11 0580 / 11 0581

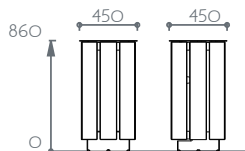

Furniture shown is in **ash**  
with clear autoclave treatment



Litter bin | REIMS (51 - France)

## > Bicycle guard

L. 595 mm / P. 50 mm / H. 800 mm - 4 anchoring points - weight 7 kg

.....

Ref. 11 0560

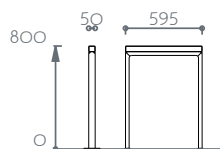

Furniture shown is in **ash**  
with clear autoclave treatment



Bicycle guards | BÈGLES (33 - France)

# Sineu Graff, urban furniture for modern lifestyles

Designed in collaboration with urban planning and living together professionals, this furniture is a concrete response to changes in the use of public space.

**Manufactured in France** by Sineu Graff teams, **we integrate all the skills and know-how** to ensure the quality and durability of our products.

**Sineu Graff offers a wide range of solutions,** from **classic furniture** to **modular furniture** and **collections in the functionalities of :**

- Rest and leisure,
- Waste management,
- Protection and safety,
- Tree protection,
- Urban planting,
- Healthy leaving.

And **services :**

- Through the **know-how of our Design and Innovation Research Department**, at the service of specific strategic projects
- By the **installation and implementation** of the furniture,
- By the **after-sales service**



**ADDITIONAL  
INFORMATION**

[www.sineugraff.com](http://www.sineugraff.com)

## **Sineu Graff**

Founded in 1971

President Vincent Schaller

## **Production area integrated into the headquarters:**

10 000 m<sup>2</sup>

## **Strong sales presence:**

- 2 000 customers in France and abroad
- integrated sales network in France
- an export manager
- a marketing department
- a customer service
- an international network of distributors
- offices in 30 different countries

## **Customer service**

[contact@sineugraff.com](mailto:contact@sineugraff.com)

Tel.: + 33 (0)3 88 58 74 58

## **Photographs**

Stéphane Louis

Anne Lena Tande Sandersen

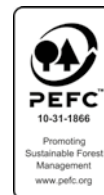



253 A, rue d'Epfig - F-67230 Kogenheim - France  
Tel. +33 (0)3 88 58 74 58 · Fax +33 (0)3 88 74 01 00 · [contact@sineugraff.com](mailto:contact@sineugraff.com)  
[www.sineugraff.com](http://www.sineugraff.com)

